

Transformer A40b_18-44

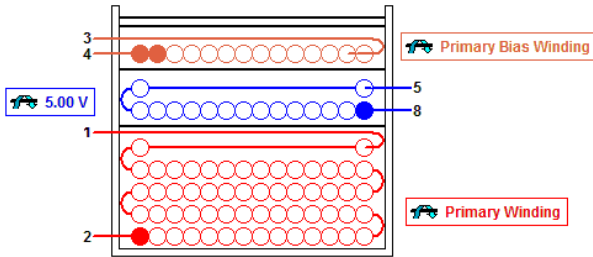
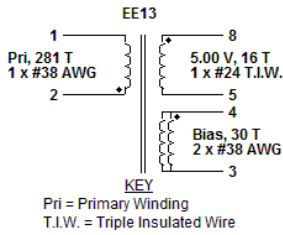

KEY

- Mechanical start of winding (also denotes electrical phase)
- 🌀 Direction of winding (clockwise)

Winding Instruction

| |
|---|
| Primary Winding |
| Start on pin(s) 2 and wind 281 turns (x 1 filar) of item [5]. in 5 layer(s) from left to right. Winding direction is clockwise. At the end of 1st layer, continue to wind the next layer from right to left. At the end of 2nd layer, continue to wind the next layer from left to right. Continue the same way as in previous 2 layers. On the final layer, spread the winding evenly across entire bobbin. Finish this winding on pin(s) 1. |
| Add 1 layer of tape, item [3], for insulation. |
| Secondary Winding |
| Start on pin(s) 8 and wind 16 turns (x 1 filar) of item [6]. Spread the winding evenly across entire bobbin. Winding direction is clockwise. Finish this winding on pin(s) 5. |
| Add 2 layers of tape, item [3], for insulation. |
| Primary Bias Winding |
| Start on pin(s) 4 and wind 30 turns (x 2 filar) of item [5]. Winding direction is clockwise. Spread the winding evenly across entire bobbin. Finish this winding on pin(s) 3. |
| Add 1 layer of tape, item [3], for insulation. |
| Core Assembly |
| Assemble and secure core halves. Item [1]. |
| Varnish |
| Dip varnish uniformly in item [4]. Do not vacuum impregnate. |

Comments

1. For non margin wound transformers use triple insulated wire for all secondary windings.

Materials

| Item | Description |
|------|---|
| [1] | Core: EE13, Yes, gapped for ALG of 29 nH/T ² |
| [2] | Bobbin: Generic, 4 pri. + 4 sec. |
| [3] | Barrier Tape: Polyester film [1 mil (25 µm) base thickness], 7.60 mm wide |
| [4] | Varnish |
| [5] | Magnet Wire: 38 AWG (0.1 mm), Solderable Double Coated |
| [6] | Triple Insulated Wire: 24 AWG (0.55 mm) |

Electrical Test Specifications

| Parameter | Condition | Spec |
|--------------------------------|---|---------------------------|
| Electrical Strength, VAC | 60 Hz 1 second, from pins 1,2,3,4 to pins 5,8. | 3000 |
| Nominal Primary Inductance, µH | Measured at 1 V pk-pk, typical switching frequency, between pin 1 to pin 2, with all other Windings open. | 2266 |
| Tolerance, ±% | Tolerance of Primary Inductance | 10.0 |
| Maximum Primary Leakage, µH | Measured between Pin 1 to Pin 2, with all other Windings shorted. | measured leakage : ~250uH |

⚡ XT2 - 200VAC VDS waveforms // full load - 700mA @ 5.5VDC // no load - <5mA

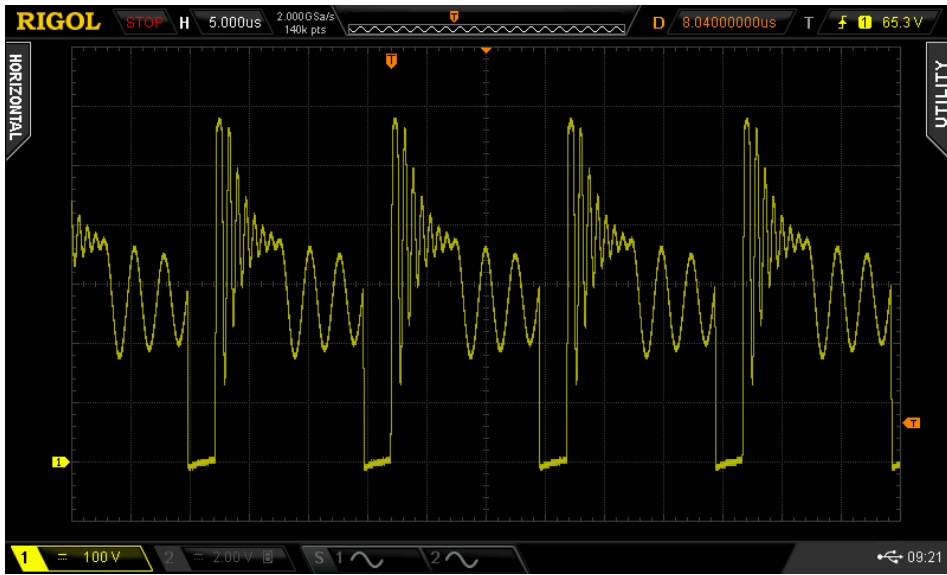

Full load

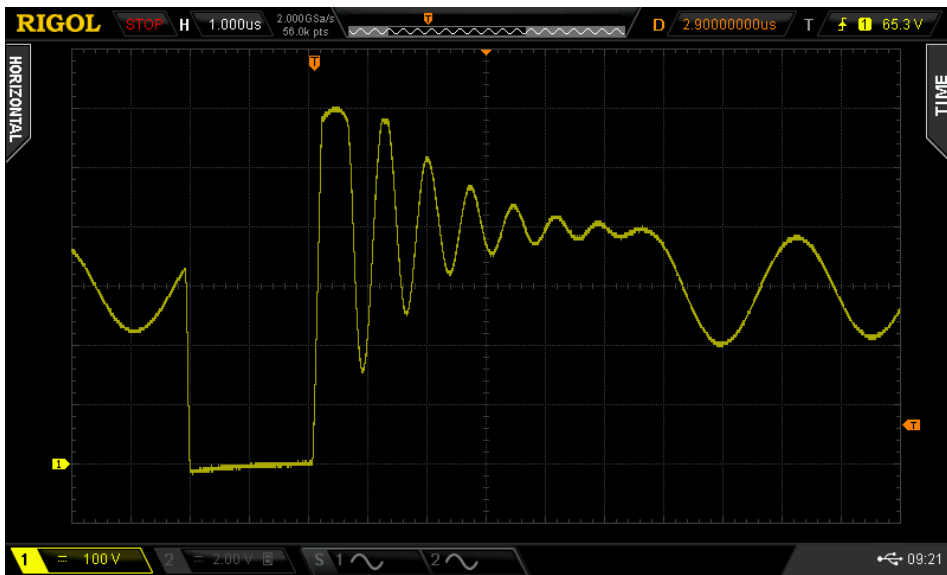

Full load

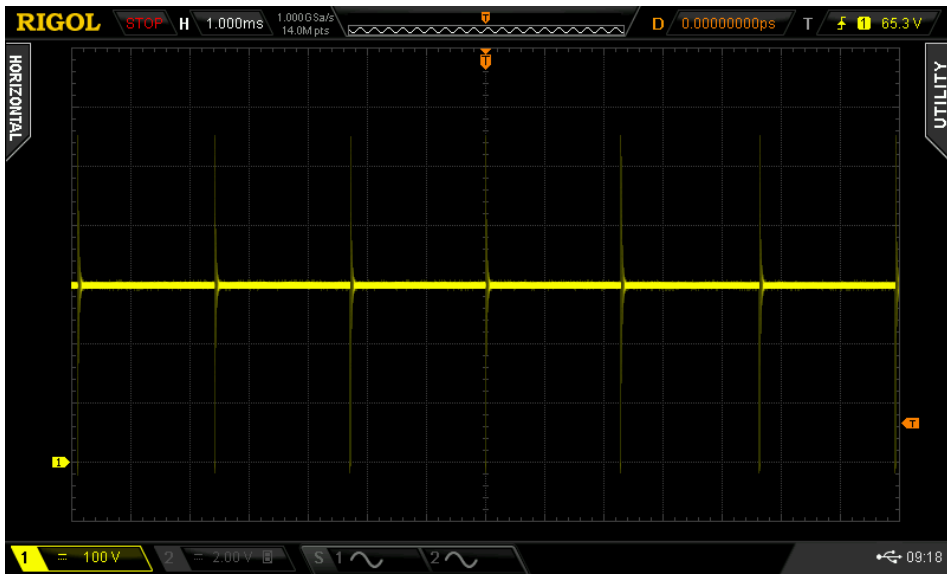

No load

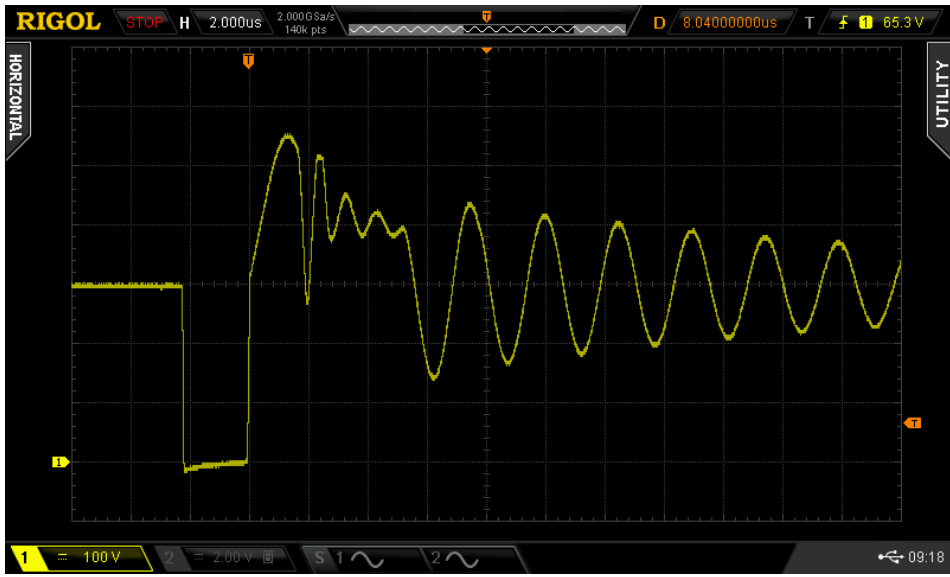

No load

XT2 - 400VAC VDS waveforms // full load - 700mA @ 5.5VDC // no load - <5mA

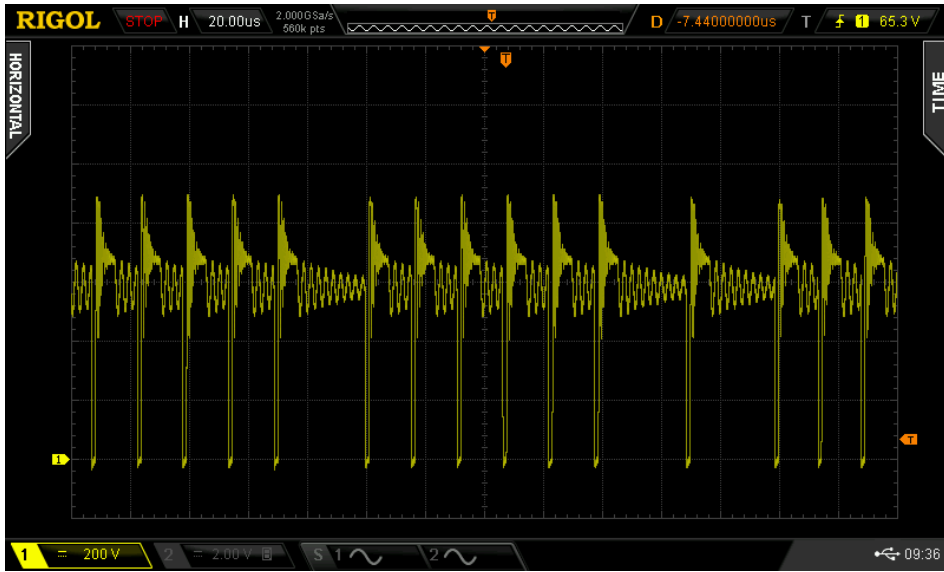

Full load

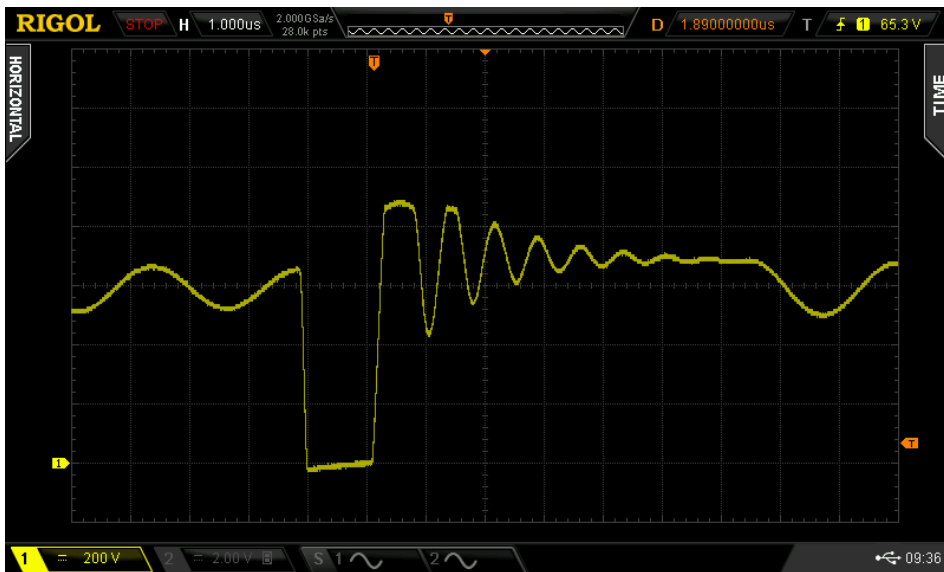

Full load

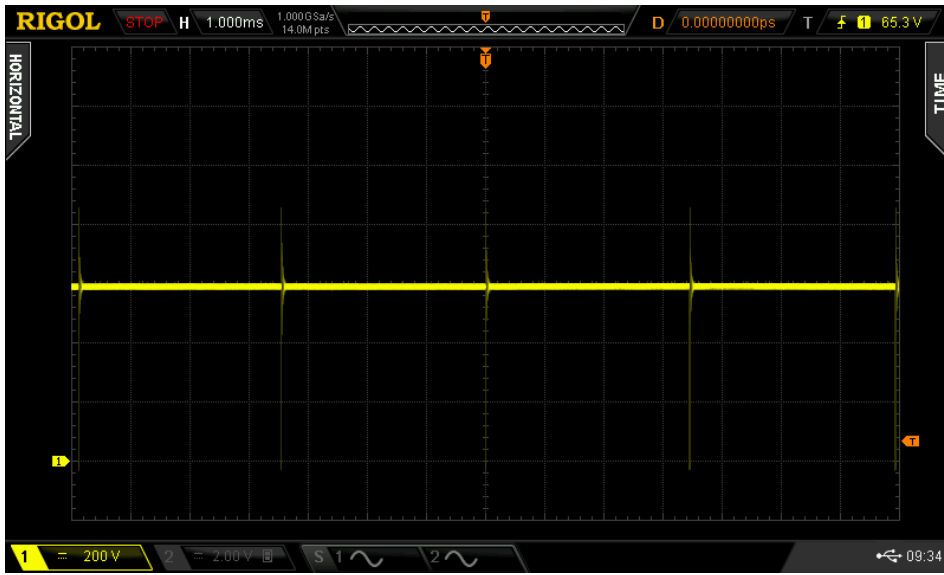

No load

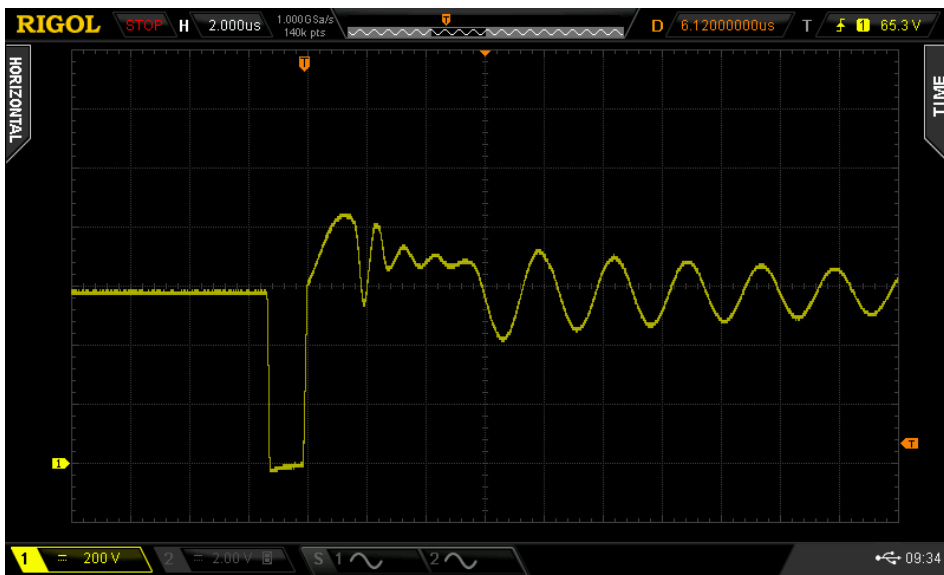

No load

Schematic

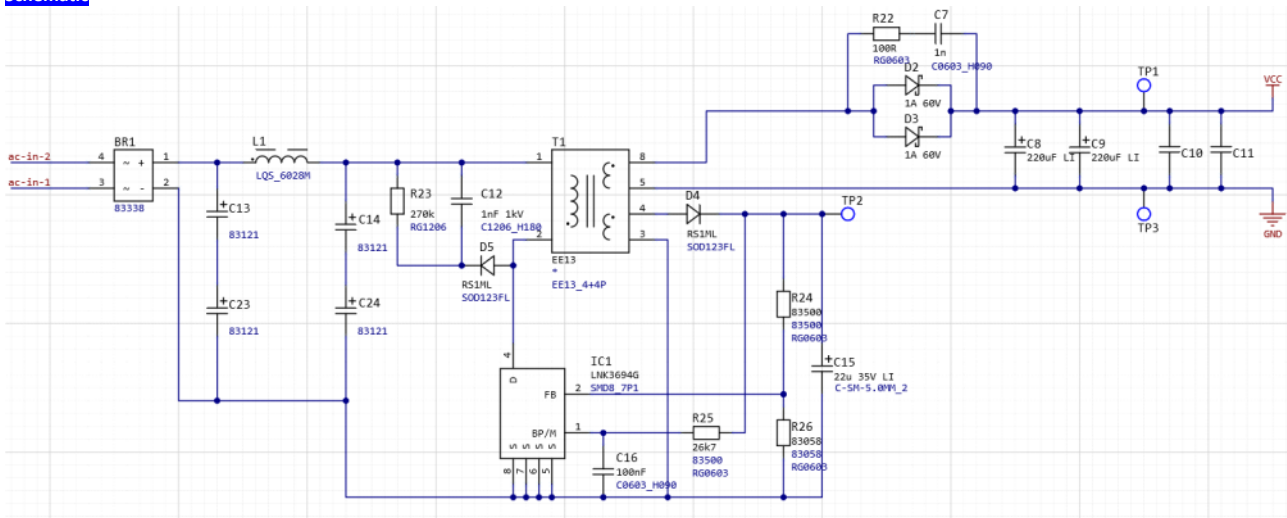

Layout

